

Binghamton Metropolitan Transportation Study

PO Box 1766
 Binghamton, NY 13902
Your Tagline Here

Bobby Portorsnok
 Chenango and Bevier
 Binghamton
 First Outside Count Fairly nice

File Name : Chenango and Bevier AM 2015
 Site Code : 40
 Start Date : 5/7/2015
 Page No : 1

Groups Printed- Unshifted - Heavy Vehicles

Start Time	From North					From East					From South					From West					Int. Total
	Right	Thru	Left	Peds	App. Total	Right	Thru	Left	Peds	App. Total	Right	Thru	Left	Peds	App. Total	Right	Thru	Left	Peds	App. Total	
02:45 PM	26	3	51	0	80	38	63	1	0	102	6	13	5	0	24	2	59	38	6	105	311
Total	26	3	51	0	80	38	63	1	0	102	6	13	5	0	24	2	59	38	6	105	311
03:00 PM	29	5	45	1	80	26	62	3	5	96	3	7	0	1	11	2	43	22	8	75	262
03:15 PM	39	2	37	2	80	30	77	0	2	109	6	3	2	0	11	1	75	30	6	112	312
03:30 PM	36	4	42	0	82	46	74	4	4	128	3	11	4	1	19	3	63	24	4	94	323
03:45 PM	39	7	57	3	106	40	72	0	2	114	2	3	4	0	9	7	63	27	1	98	327
Total	143	18	181	6	348	142	285	7	13	447	14	24	10	2	50	13	244	103	19	379	1224
04:00 PM	40	4	67	3	114	28	78	3	1	110	5	4	3	0	12	1	64	28	0	93	329
04:15 PM	39	9	36	1	85	21	27	2	8	58	4	5	1	0	10	0	45	28	0	73	226
04:30 PM	40	14	63	2	119	45	73	3	0	121	10	6	5	0	21	1	95	39	3	138	399
04:45 PM	37	6	60	1	104	31	84	4	0	119	3	7	3	1	14	1	74	35	2	112	349
Total	156	33	226	7	422	125	262	12	9	408	22	22	12	1	57	3	278	130	5	416	1303
05:00 PM	37	8	61	1	107	36	84	2	2	124	4	7	4	0	15	1	80	20	3	104	350
Grand Total	362	62	519	14	957	341	694	22	24	1081	46	66	31	3	146	19	661	291	33	1004	3188
Approch %	37.8	6.5	54.2	1.5		31.5	64.2	2	2.2		31.5	45.2	21.2	2.1		1.9	65.8	29	3.3		
Total %	11.4	1.9	16.3	0.4	30	10.7	21.8	0.7	0.8	33.9	1.4	2.1	1	0.1	4.6	0.6	20.7	9.1	1	31.5	
Unshifted	357	62	503	14	936	331	681	22	24	1058	46	65	31	3	145	18	652	286	33	989	3128
% Unshifted	98.6	100	96.9	100	97.8	97.1	98.1	100	100	97.9	100	98.5	100	100	99.3	94.7	98.6	98.3	100	98.5	98.1
Heavy Vehicles																					
% Heavy Vehicles	1.4	0	3.1	0	2.2	2.9	1.9	0	0	2.1	0	1.5	0	0.7	5.3	1.4	1.7	0	1.5	1.9	

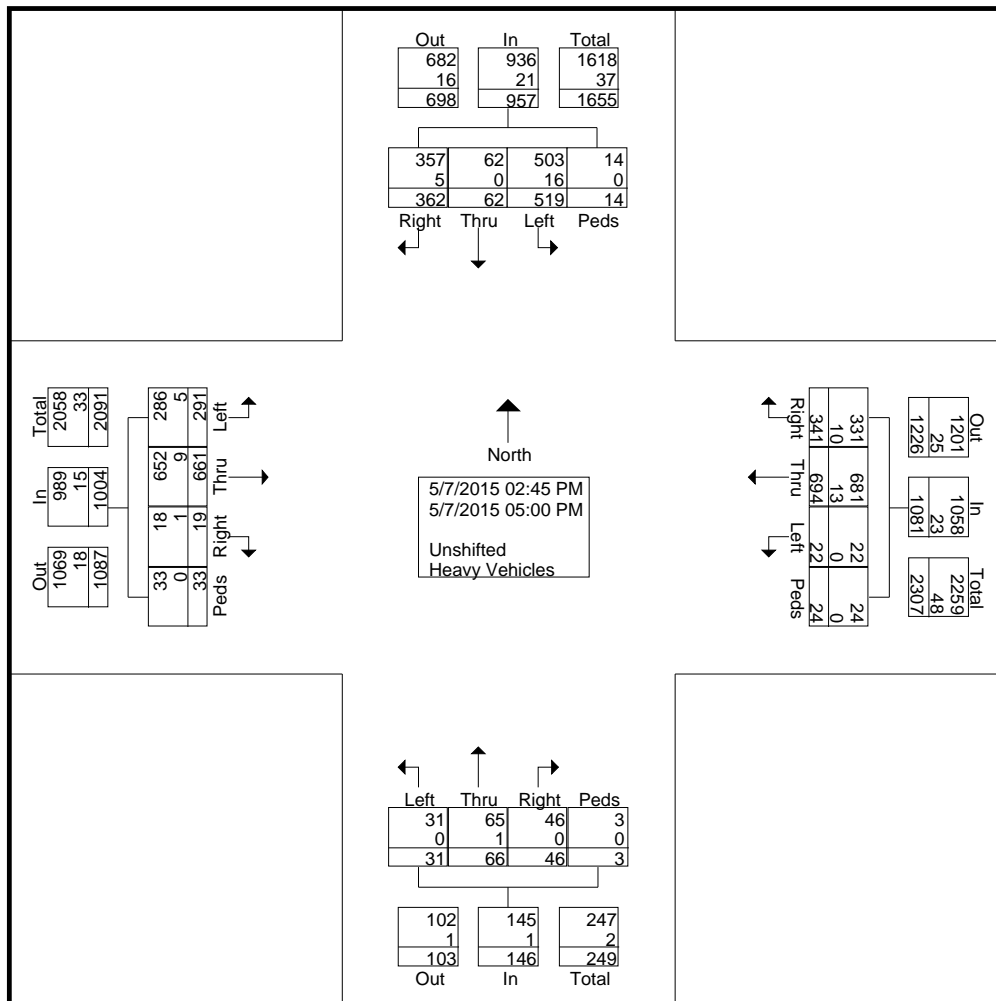

Binghamton Metropolitan Transportation Study

PO Box 1766
Binghamton, NY 13902

Your Tagline Here

Bobby Portorsnok
Chenango and Bevier
Binghamton
First Outside Count Fairly nice

File Name : Chenango and Bevier AM 2015
Site Code : 40
Start Date : 5/7/2015
Page No : 2

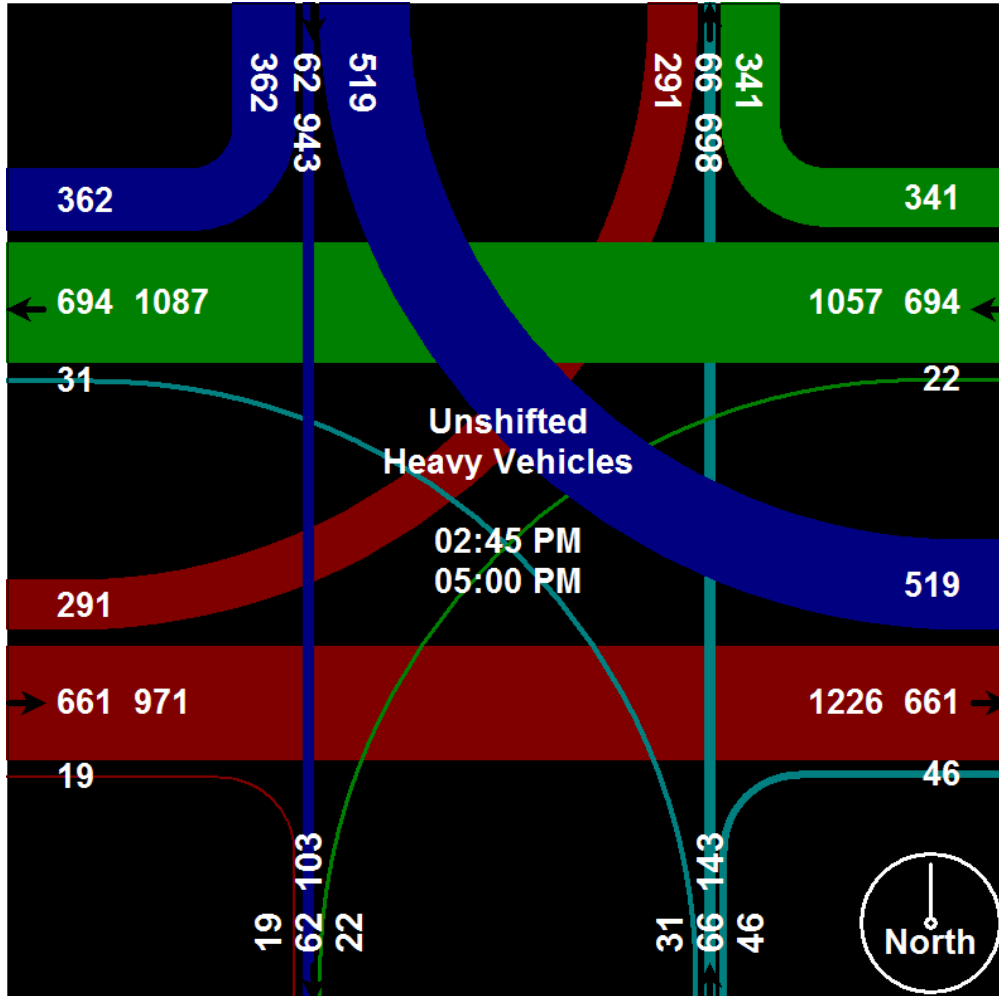

Binghamton Metropolitan Transportation Study

PO Box 1766
 Binghamton, NY 13902
Your Tagline Here

Bobby Portorsnok
 Chenango and Bevier
 Binghamton
 First Outside Count Fairly nice

File Name : Chenango and Bevier AM 2015
 Site Code : 40
 Start Date : 5/7/2015
 Page No : 3

Start Time	From North					From East					From South					From West					Int. Total
	Right	Thru	Left	Peds	App. Total	Right	Thru	Left	Peds	App. Total	Right	Thru	Left	Peds	App. Total	Right	Thru	Left	Peds	App. Total	
Peak Hour Analysis From 02:45 PM to 05:00 PM - Peak 1 of 1																					
Peak Hour for Entire Intersection Begins at 04:15 PM																					
04:15 PM	39	9	36	1	85	21	27	2	8	58	4	5	1	0	10	0	45	28	0	73	226
04:30 PM	40	14	63	2	119	45	73	3	0	121	10	6	5	0	21	1	95	39	3	138	399
04:45 PM	37	6	60	1	104	31	84	4	0	119	3	7	3	1	14	1	74	35	2	112	349
05:00 PM	37	8	61	1	107	36	84	2	2	124	4	7	4	0	15	1	80	20	3	104	350
Total Volume	153	37	220	5	415	133	268	11	10	422	21	25	13	1	60	3	294	122	8	427	1324
% App. Total	36.9	8.9	53	1.2		31.5	63.5	2.6	2.4		35	41.7	21.7	1.7		0.7	68.9	28.6	1.9		
PHF	.956	.661	.873	.625	.872	.739	.798	.688	.313	.851	.525	.893	.650	.250	.714	.750	.774	.782	.667	.774	.830

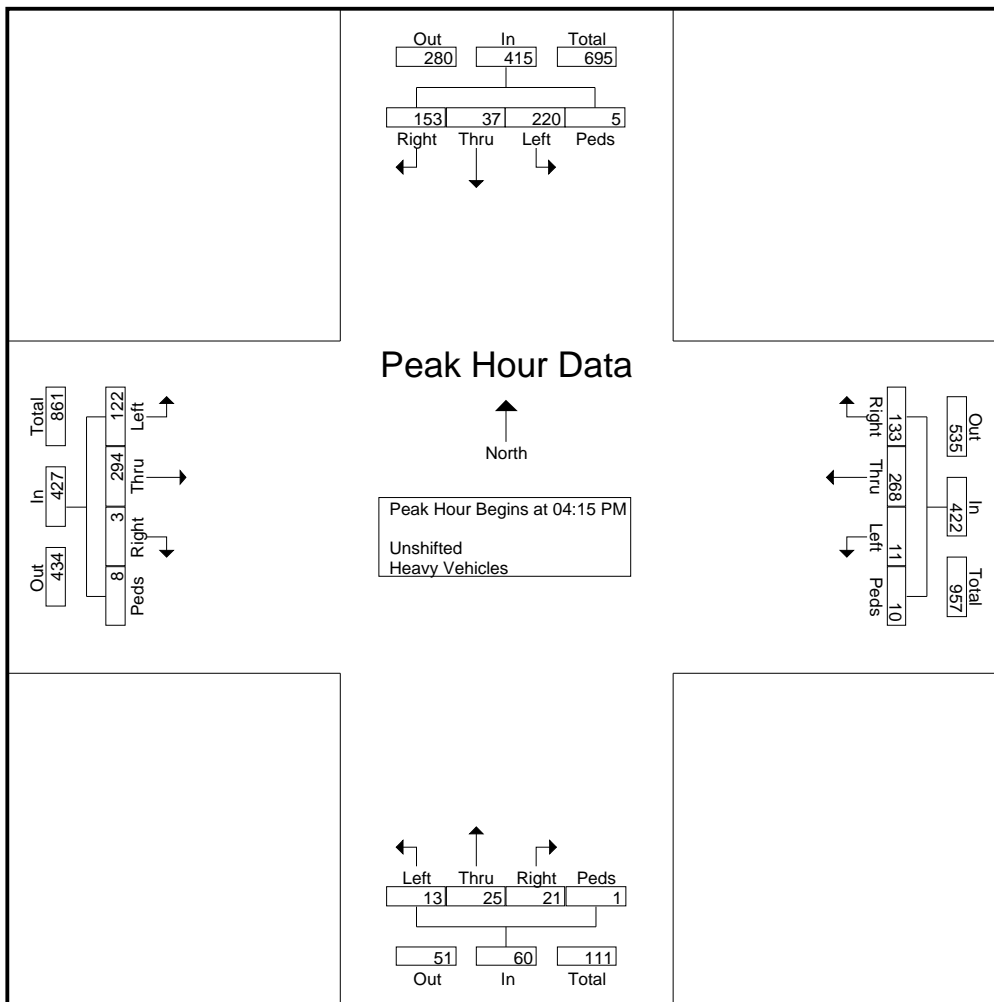

Binghamton Metropolitan Transportation Study

PO Box 1766
 Binghamton, NY 13902
Your Tagline Here

Bobby Portorsnok
 Chenango and Bevier
 Binghamton
 First Outside Count Fairly nice

File Name : Chenango and Bevier AM 2015
 Site Code : 40
 Start Date : 5/7/2015
 Page No : 4

Start Time	From North					From East					From South					From West					Int. Total
	Right	Thru	Left	Peds	App. Total	Right	Thru	Left	Peds	App. Total	Right	Thru	Left	Peds	App. Total	Right	Thru	Left	Peds	App. Total	
Peak Hour Analysis From 02:45 PM to 05:00 PM - Peak 1 of 1																					
Peak Hour for Each Approach Begins at:																					
	03:45 PM					03:15 PM					02:45 PM					04:15 PM					
+0 mins.	39	7	57	3	106	30	77	0	2	109	6	13	5	0	24	0	45	28	0	73	
+15 mins.	40	4	67	3	114	46	74	4	4	128	3	7	0	1	11	1	95	39	3	138	
+30 mins.	39	9	36	1	85	40	72	0	2	114	6	3	2	0	11	1	74	35	2	112	
+45 mins.	40	14	63	2	119	28	78	3	1	110	3	11	4	1	19	1	80	20	3	104	
Total Volume	158	34	223	9	424	144	301	7	9	461	18	34	11	2	65	3	294	122	8	427	
% App. Total	37.3	8	52.6	2.1		31.2	65.3	1.5	2		27.7	52.3	16.9	3.1		0.7	68.9	28.6	1.9		
PHF	.988	.607	.832	.750	.891	.783	.965	.438	.563	.900	.750	.654	.550	.500	.677	.750	.774	.782	.667	.774	

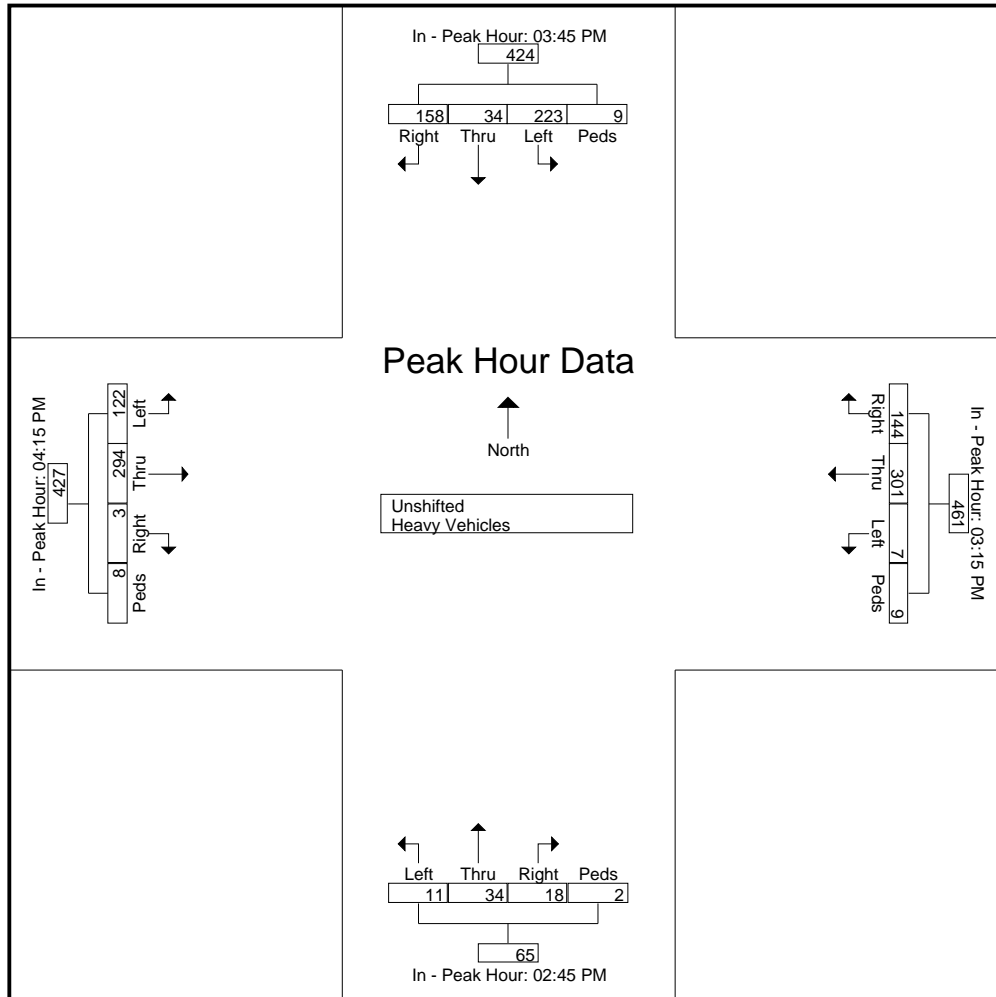

Binghamton Metropolitan Transportation Study

PO Box 1766
Binghamton, NY 13902

Your Tagline Here

Bobby Portorsnok
Chenango and Bevier
Binghamton
First Outside Count Fairly nice

File Name : Chenango and Bevier AM 2015
Site Code : 40
Start Date : 5/7/2015
Page No : 5

